

2-Way Diaphragm Valves

The standard 2-way valve body is the basic building block of diaphragm valve technology. Its design and characteristics make it the ideal choice for all categories of clean processing systems. Optional materials, surface finish specifications (in compliance with ASME BPE) and international tube designations are all available to suit your application/specification criteria.

Saunders Valve Body Highlights

- Cavity free and self draining
- Isolating diaphragm, top entry design, and positive closure
- Controlled sulphur forged bodies (0.005% ñ 0.017%) meets ASME BPE DT-3 requirement for low sulphur content
- Low maintenance costs
- Readily incorporated into valve cluster and access valve/fitting fabrications
- Materials of construction compatible to entire system
- Bubble tight closure against both pressure and vacuum
- Bi-directional flowpath
- Diaphragm valves are recognised by the biopharm industry as the only truly aseptic valve

Standard 2-Way Bodies

Saunders invented the diaphragm valve concept and then pioneered the development of the first true high purity diaphragm valve with the introduction of the AFP forged 316L/1.4435 body range. The entrapment free design and self-draining characteristics of the diaphragm valve body make it the ideal choice for both aseptic processes and systems that must be cleaned in place. Top entry design allows maintenance while the valve is installed and permits the valve to be welded in place reducing the required number of mechanical joints and enhancing system security.



Drainability

- Valve size and end specification
- Internal surface finish
- Drain orientation (as shown)
- Surface tension and viscosity of media
- Pipe run angle - generally recommended at 2 to 3 degrees

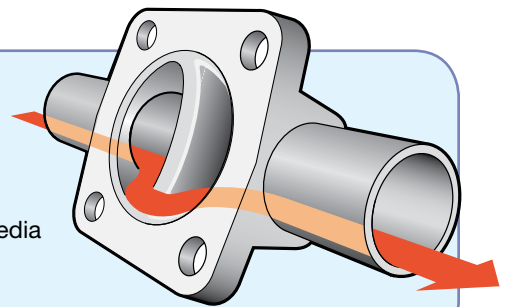

Standard 2-Way Valves

Pure performance forged valves*	8 - 15 mm
Forged stainless steel valves*	15 - 80 mm
Solid block stainless steel valves	100 - 150 mm
Cast stainless steel valves	8 - 100 mm

* Compliant with ASME BPE Table DT-3 for low sulphur requirement

Chemical Composition - HC4 AFP Forgings

1.4435/316L	EN 10222-5	ASTM A-182	ASME BPE Table DT-3
Element	%	%	%
Carbon	0.03 max.	0.03 max.	0.03 max.
Silicon	1.00 max.	1.00 max.	1.00 max.
Manganese	2.00 max.	2.00 max.	2.00 max.
Phosphorus	0.04 max.	0.04 max.	0.04 max.
Sulphur	0.025 max.	0.005/.017	0.005/.017
Chromium	17.0/18.0	17.0/18.0	17.0/18.0
Nickel	12.5/13.5	12.5/13.5	12.5/13.5
Molybdenum	2.5/3.0	2.5/3.0	2.5/3.0
Nitrogen	0.11	0.11	0.11

Pure Performance (Bio-Seal) Forged Bodies (DN8 - DN15)

Forged Stainless Steel Bodies (DN15 - DN80)

Investment Cast Stainless Steel Bodies (DN8 - DN100)

Machined from Block Standard Valve Bodies (DN100 - DN150)

Controlled Sulphur Forged Bodies (DN8-DN80)

Saunders

HC4 Standard Machined Block Valves



The Saunders range of HC4 Standard Machined Block valves uniquely provides the user with compact, minimum deadleg construction, full drainability, flexible high-integrity configuration and, ultimately, security of processing.

Zero Deadleg 'T' Pattern

Essential for the elimination of dead legs and designed to ease installation and validation, Saunders Zero Deadleg T pattern range (ZDT) enhances the integrity of critical systems.

Machined integrally from a forging, the ZDT normally features three common ports with the same bore dimensions and incorporates a valve body and tee fitting into a single solution. ZDT valves form the ideal solution for feeding laterals off recirculating loops, sample points or use point applications. The bodies can be supplied with weld or hygienic clamp end connections or included in a U-bend configuration for point-of-use service.

Major benefits of the range include:

- Virtual elimination of deadleg to enhance process integrity
- Highly compact, space saving design providing ideal solution where space is a concern
- Excellent drainage characteristics to facilitate quick and effective sterilisation
- Patented design to aid validation for FDA and cGMP compliance
- Machined integrally from Stainless Steel 316L/1.4435 forging (no welds)
- Available in size range DN15 to DN50 with full range of FDA conforming diaphragm/bonnet/actuation options

Close-Coupled Branch Valves

The Saunders Close Coupled Branch Valve (CCBV) complements the patented ZDT design by facilitating larger main line size options. They provide the ideal solution when the main process line is at least one size larger

than the valve/branch size. The unique tee construction is engineered from a machined billet to enhance structural integrity and ease installation and validation.

Major benefits of the range include:

- Compact flexible design providing excellent drainage characteristics and absence of deadleg
- Machined block construction provides security of installation, rapid sterilisation and easier regulatory compliance
- Ideal solution when main process line is larger than valve/branch size (i.e. main line DN50 valve/branch DN25) utilises DN25 diaphragm/bonnet/ actuator
- Sampling/injection points on high purity water systems

Point-of-Use Options (Close-Coupled Branch Valve 'U' Bend)

One of the most sensitive applications in a WFI loop is the use point valve. These valves represent the barrier between the safety of the recirculating loop and the potential hazards of the environment and function as the take off point for consumption of WFI. Valves for this application need the highest level of design security, integrity and cleanliness. Saunders point-of-use valves are engineered to minimise dead areas and fully drain all associated tubing.

Multi-port Diverter Valves

Modern machining technology is employed in the design and manufacture of Saunders range of Bio-Block diverter valves.



Significant advantages:

- Machined Block construction, free from fabrication welds to enhance structural integrity
- Minimal deadleg design to reduce risk of process contamination
- Inlet machined integrally eliminates a potential source of contamination (many other designs employ bolted inlet)
- Excellent drainage characteristics for quick and effective sterilisation
- Reduced space requirement provides greater flexibility in system design and simplified installation
- Complete solution including FDA compliant diaphragms, manual bonnets and actuators
- Fully certified range, with comprehensive validation support documentation on request

Integral Sampling Ports

Saunders Close Coupled Branch Valves (both T and U bend) can be supplied with optional integral sample ports to permit real-time sampling of WFI without breaking a sterile use point connection.



This provides a number of key process advantages:

- Minimum product envelope
- Minimum deadleg
- Less system welds

Tank Bottom Valves

The Saunders tank bottom valve incorporates the performance and features of a diaphragm valve into a one piece fully forged tank outlet design.

HC4 Customised Fabrication Options

For applications where a standard machined block valve is not sufficient, but a full custom solution is not required, there is a wide variety of fabricated options that will provide the optimum valve configuration.

Tandem Valves (Sterile Access Valves)

Welded Valve Fabrications

The first and still most common customised valve concept is the tandem valve or valve and fitting combination.

The following rules help define the possible orientation of tandem valves:

- The main valve and access valve may be installed to drain in either the horizontal or vertical position. When installed in a horizontal run the valve must be rotated into the self-drain position to drain
- Allowance must be made to permit access to bonnet or actuator fasteners and for diaphragm maintenance
- The access valve can be any size including the same size as the main valve
- The amount of dead leg between main and access valves will vary depending on respective valve sizes and orientation. Virtually all combinations fall within cGMP requirements
- 'Handwheel opposite' designs generally have shorter tangents than configurations with the handwheel of the main and access valves in the same quadrant
- All Saunders welded valve fabrications are 100% hydro-tested before and after all welding and polishing processes to ensure mechanical integrity. Full material certification of all tube and fittings utilised is standard
- Saunders bonnets, actuators and diaphragms fit fabricated valve assemblies without adaptors or distance pieces

Saunders

A main valve is ported and a section of tube is welded to the port to create an access point into the valve. This tube can in turn be welded to a second valve forming a two-valve cluster, or the tube can be turned into a weld end, hygienic clamp or other type of fitting. The fabrication weld is polished to match the required surface finish specification. The resulting assembly is designed to optimise drainability and meet standard process considerations including cGMPs for dead legs.

Applications include flow diversion, sampling, steam injection or condensate drain and block and bleed applications.

E Tools

Electronic tools exist to assist customers in the selection and orientation of these fabrications. Saunders Tandem Valve Selection Programme enables engineers and design detailers to select the optimum orientation to suit system requirements and produce a fully coded 3D graphic for immediate translation to valve manufacture.



ZDL Zero Deadleg Valve 'L' Pattern

The Saunders ZDL 'L' pattern diaphragm valve is typically installed in a vertical line. The functions of a 90 degree fitting and a take-off valve are combined within the valve body. The bore of the third port is situated in line with the point of seal where the diaphragm meets the weir. This ensures low point drainability and elimination of deadlegs.



Valve Manifolds/Clusters

Configuration of optimum process fabrication presents system designers with an ongoing challenge. Minimum space envelope, reduced hold up areas, reduced cost and facilitating ease of installation are all key considerations.

- Manufactured under stringent ISO 9001:2000 quality control
- Tailor-made solutions to customer requirements
- Fully tested assembled units manufactured under controlled conditions
- Full traceability of all components

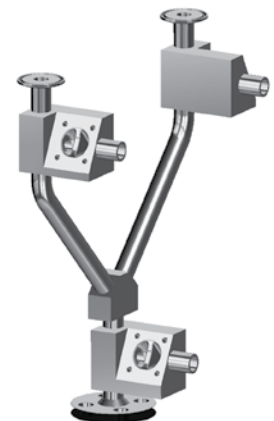

Saunders



HC4 Bio-Block Customised Design Solutions

Almost every process system includes a unique piping challenge that does not lend itself to conventional solutions. Saunders custom designed HC4 Bio-Block valves replace welded clusters, manifolds and valve/fitting combinations and offer the most compact, minimum deadleg design for optimum process integrity.

Computer Aided Design Capability (CAE) Bio-Block Standard & Compound Valves

Our design teams work closely with customers to create unique machined valve designs that we call Bio-Blocks. These 'outside of the box' solutions may be driven by process, space constraints, regulatory issues or other specific requirements. The key element in producing Bio-Block valve solutions has been the development

of advanced CAE (Computer Aided Engineering) design and manufacturing tools that enable our engineers to convert concept into reality. This approach to manufacturing provides custom machined valve products with the shortest possible lead times in design and production. We work closely with customers to co-ordinate solutions to unique application challenges. All custom Bio-Block valve bodies accept Saunders standard diaphragms, bonnets and actuators without modification or adaptors. The compact design of the EC actuator range enables us to produce the most space-efficient solutions in the industry.

Machined Bio-Blocks have the advantages of reduced wetted area and dead-legs, no internal fabrication welds and reduced documentation for installation and validation. Faster and easier installation of process manifolds can be achieved using advanced imachined from solid valves.

HC4 Diaphragms

The critical component of any diaphragm valve is the diaphragm itself, due to its function as a dynamic seal and its continuous contact with highly valuable process media. Through continuous in-house development of our core expertise in this area, the Saunders brand provides customers with class-leading, traceable solutions to meet the most stringent process needs.

The Diaphragm - Key to Successful Valve Performance

The diaphragm is the key performance component within a diaphragm valve. The diaphragm forms both the differential and atmospheric seal and isolates the topworks from the process media.

Saunders continues to lead the diaphragm valve industry in the development and manufacture of elastomer components based on our in-house core competence in rubber and plastic technologies. We remain the only manufacturer to have front to back ownership of all aspects of



polymer research and development, diaphragm design and production. We offer a full range of diaphragm selections engineered to meet the exacting demands of the pharmaceutical industry. PTFE, TFM and elastomer types are available to suit individual system requirements.

All Saunders brand aseptic diaphragms are formulated in-house and manufactured from FDA conforming materials to meet the requirements of CFR (Code of Federal Regulations) Chapter 1 Title 21 and are tested and certified to USP Classes V and VI. Certificates of Conformity to FDA and USP are available upon request.



All diaphragms within the range are certified ADCF (Animal Derivative Component Free) and conform to FDA regulations.



HC4 Diaphragms

Diaphragm specifications

Grade	Material	Colour	Size Range Lower-upper	Continuous temperature	Hardness IRHD	Tensile Strength	Approvals		
							FDA	3A	USP
300	Resin cured butyl rubber (isobutylene/isoprene)	Black	DN8-DN200	-30 to 130	62-68°	12.9	v	v	v
425	Ethylene Propylene, co-polymer, peroxide cured	Black	DN8-DN100	-40 to 140	61-67°	12	v	v	v
325	(*)								
E5	(*)								
E3	Ethylene Propylene, co-polymer peroxide cured, post cured	Black	DN8-DN100	-40 to 140	61-67°	12	v	v	v
E4	Ethylene propylene (EPDM) diene-modified, peroxide cured	White	DN8-DN100	-40 to 110	60-66°	11	v	-	-
214/300	PTFE/Butyl backed	White facing, black backing	DN8-DN200	-20 to 150	-	32	v	v	v
214/425	PTFE/EPM backed	White facing, black backing	DN8-DN200	-20 to 160	-	-	v	v	v
214S/425*	PTFE/EPM backed for steam	White facing, black backing	DN8-DN200	-20 to 160	-	-	v	v	v
214/325									
500	Silicone DBPH cured	White	DN8-DN200	-40 to 150	67-73°	7.1	v	v	-
214S/300	PTFE/Butyl backed for steam	White facing, black backing	DN8-DN200	-20 to 150	-	30	v	v	v
214S/325	(*)								

* DN8-50 conforms to new Hi-Steam design / ** superceded by new enhanced EPDM

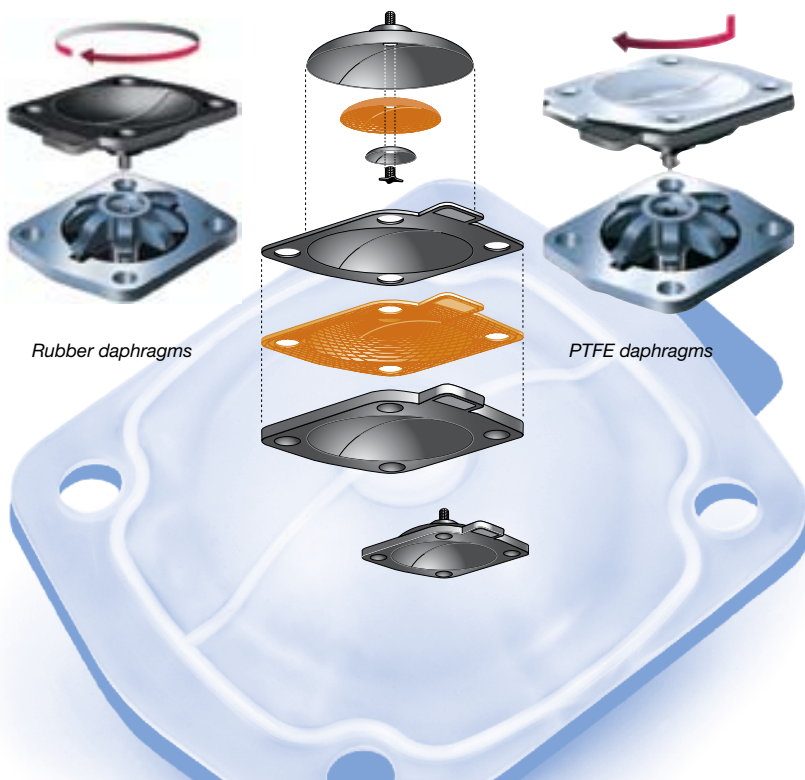

The main categories of aseptic diaphragms are:

Synthetic elastomer - black internally reinforced grades

- Grade 300 - Butyl
- Grade 425 - EPM, peroxide cured
- Grade E3 - EPM, peroxide cured, post cured

Synthetic elastomer - white internally reinforced grades

- Grade 500 - Silicone
- Grade E4 - EPDM peroxide cured

PTFE

- PTFE virgin grade white, grade 214 with either 300, 325 or 425 backing support
- TFM white, grade 214S with 325 or 425 backing

HC4 Diaphragms



Saunders

Type 425 Grade EPM diaphragms

Delivers highest levels of performance and security for the most demanding biopharmaceutical applications

- Manufactured from inherently stable EPM (A copolymer of Ethylene and Propylene monomers)
- Uses the latest vulcanisation technology
- Enhanced temperature performance and chemical resistance due to the elimination of any double bond active sites as displayed with EPDM molecular structure
- Improved steam life cycle and flex life
- Longer lasting diaphragm provides better reliability with less disruption to pharmaceutical processes
- Fully complies with all international standards for toxicity and purity as defined by regulatory bodies such as FDA, USP and ISO is confirmed by independent laboratory studies
- Full traceability documentation available to confirm specific batch number and critical data. This aids validation, assists in trouble shooting and is a guarantee of product quality
- Certified as ADCF (Animal Derivative Component Free) to ensure maximum product purity and integrity



Full Traceability

To assist in the validation process and to provide the highest level of reliability, security and regulatory compliance, we provide full batch traceability for all grades of aseptic diaphragms.

Key elements in diaphragm design and selection include:

- Media compatibility
- Levels of extractables
- Flex and closure performance
- Resistance to compression set
- Longevity
- Regulatory conformance

Our elastomer technology and application engineering specialists are available to consult on specifics of material selection.

The Saunders range of FDA conforming diaphragms has been designed to meet the highest standards of performance and reliability based on current elastomer and plastics technology. Equally important is the associated documentation support to assist regulatory compliance and aid plant and system validation.

Only the Saunders brand matches diaphragm quality and performance with the highest standard of documentation and validation support.

Saunders

HC4 Top Works Manual Bonnets, Actuators & Accessories

The Saunders HC4 range of manual and actuated Top Works provides industry-leading features with ergonomic, compact design. Ease of operation and high temperature resistant materials (polymer and stainless steel) compliment a wide choice of modular options.

Black PES (Polyethersulphone) Performance Bonnet

Designed for the most demanding applications and featuring PES, a high performance thermoplastic material with excellent chemical resistance, to ensure long life and high reliability.

Fully autoclavable, the PES bonnet is available across the size range DN15-DN80.

Key Features:

- High integrity, ergonomic handwheel. Design ensures comfortable operation and precise control
- Fully autoclavable to 140°C
- 'O' Ring seal prevents both the escape of product and the potential ingress of contaminants
- Shrouded bonnet construction provides maximum containment and diaphragm support for critical applications

- Modular options available including padlocking facility, proximity sensors, 'V' notch vent plugs and limit open stop version
- Fully FDA conforming materials of construction
- Limit closing stop to provide process/flow control option

Padlock Option

The padlocking facility can be supplied to order or is available in kit form for retro-fitting to the bonnet sub-assembly or whole valve.

Limit open stop option

Limit open stop bonnet to facilitate effective running of system under normal capacity.

Limit closing stop option

A fully adjustable limit closing stop is fitted as standard to all Performance bonnets. The limit closure stop is located under the handwheel and is adjusted by first removing the handwheel fixing screw and the handwheel assembly.



Compact Actuators that provide reliable remote control

Saunders EC and SSC Pneumatic Actuators facilitate remote operation of the valve, either as a simple alternative to manual bonnet assemblies or as an integral part of the control system. Both are compact piston style actuators with excellent chemical and temperature resistance.

The versatile and robust design derived from the use of high technology materials of construction, results in an actuator suitable for a wide range of process industry applications.

EC Actuator

SSC Actuator

ECX Actuator Bodies (DN8-DN80)

Pneumatic Actuators for Larger Valves; EV & ES Modular

Actuation Accessories: Overview

Model	Size Range	Style	Material	Accessories
EC	DN8-50	A, AFP	PES	Solenoid, switch box, positioner, handwheel available / air filter not available
SSC	DN8-50	A, AFP	316 C12	Solenoid, switch box, positioner, handwheel available / air filter not available
ECX	DN65-150	A, AFP	SiAl Coated	Solenoid, switch box, air filter, handwheel available / positioner not available
EV	DN15-150	A, AFP, KB	SiAl Coated	Solenoid, switch box, positioner, air filter available / handwheel not available
ES	DN15-200	A, AFP, KB	SiAl Coated	Solenoid, switch box, positioner, air filter, handwheel available

Mini Positioner

ESPositioner

Solenoid Valves

EC & SSC Limit Open Stop

Module Switchbox

007 Switchbox

SSC Manual Over-Ride



Saunders

HC4 Quality Standards, Traceability & Validation



Through continuous focus on quality, the Saunders brand offers the clean processing industries complete peace of mind. All international standards and conformance are rigidly adhered to throughout the HC4 product portfolio to assist the user in achieving secure, repeatable and reliable processing when using Saunders brand valves.

The Complete Approach to Quality

- Quality Management system registered to ISO 9001:2000 standard in which our R & D and manufacturing process are optimised to maintain our product quality and service
- TUV AD2000 Merkblatt HPO and A4 Qualifications for Saunders product manufacturing and certification
- CE marked products for compliance to European Directive ATEX 94/9/EC for Group II, Categories 2 and 3 applications
- Certified compliance to the European Pressure Equipment Directive 97/23/EC authorising Saunders to CE mark relevant valve products
- International product approval from authorities such as Bureau Veritas, American Bureau of Shipping
- Polymer/Rubber materials certified as meeting the requirements of FDA, 3A, WRAS and USP

HC4 Diaphragm Traceability & Validation

- Validation support - from raw materials to your system
- All ingredients - base polymer, filler, accelerators, etc - are manufactured from FDA conforming materials
- All diaphragms are fully batch traceable and carry a unique moulded batch identification number
- All diaphragms can be issued with a certificate of FDA conformity to assist in FDA validation and internal quality controls
- All diaphragm grades certified ADCF (Animal Derivative Component Free)
- Physical property data is also available upon request

Full traceability and product validation

- The Saunders valve range is acknowledged right across industry as being a leader in quality assurance techniques and design criteria for clean processes. The Saunders product, through its range of fully traceable diaphragms provides its users with valuable support in the validation process.
- A unique moulded reference number gives precise batch traceability
- Access is available to all relevant physical data
- Diaphragms that meet the most stringent validation requirements
- A certificate of the physical properties of each batch is issued to ensure consistency and support validation on request
- A profile of the complete physical data of each batch is available to help trouble shooting
- Complete documentation package is available for all valve components in contact with the process fluids (EN 10204 3.1 certification)



Validation Documentation:

Saunders can supply the following validation documentation on request:

- Certification of chemical composition to EN 10204 for body material
- Traceability certification for diaphragm grade
- Full validation manual (polymers)
- Surface trace certification
- USP Class V and VI diaphragm certification
- FDA conformance certification for all biopharm diaphragm grades
- Certificate of conformity to order specification
- ISO 9001:2000 certification
- Certification of testing to BS 6755-1
- EN 12266-1/2



The pneumatic Pinch Valve type VMP-Compact

Reliable and cost-effective!

The compact valve solution for the automatic shut off. For example dust, granule, powder, suspension, sewage, air venting etc.

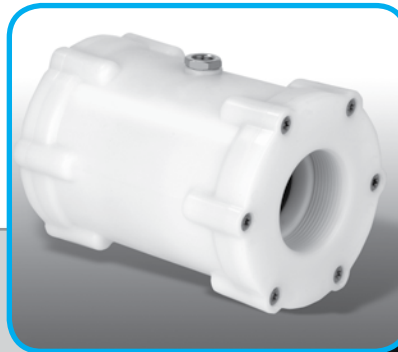

Advantages:

- Extremely compact – face to face length reduced up to 30%
- Weight reduced by 25%
- Suitable for food applications
- ATEX conformity
- Excellent weather resistance
- Complete free passage
- No plugging
- 100% tight shut off
- Easy maintenance and re-sleeving
- Free passage
- Optimum tightness
- Low resistance
- No plugging
- Low air consumption
- Low weight
- Easy maintenance

Hygiene-Right angle control valve

SCHUBERT & SALZER
CONTROL SYSTEMS

With Integrated Digital Positioner for applications in food processing

Pneumatic control valve with right angle body design and integrated microprocessor-positioner for applications in food processing and chemical.



Hygiene-Right angle control valve

DN 15 up to DN40

- Space saving, low weight design
- Body made from stainless steel barstock
- Stainless steel actuator and positioner housing options
- Metallic or soft seat options
- Zero steady-state air consumption
- Contactless stroke feedback (inductive sensor)
- Operation independent of mounting position and supply pressure variations
- Not sensitive to vibration
- Instrument grade air not essential
- Software configurable flow characteristics
- Protection class IP65

Ball and speciality valves

ERIKS has solutions for your valve application!

ERIKS works with manufacturers of ball valves, specialty valves and accessories, ERIKS recognizes that many applications are unique and may have special problems. The ideal solution combines specific application requirements with creative engineering and quality manufacturing practices.

Our valves offer the convenience of standard features with the option of customizing for a specific process. Most of our manufacturers' valves incorporate the Adjust-O-Seal® design and many include the True-Bore® port design. Only these valves have the ability to provide Clean-in-place/Steam-in-place capability without process interruption. These are just a few of the innovations that help reduce processing costs and improve efficiency for our customers.



Sanitary Valves

Our Igenix® line of sanitary valves is ideally suited for pure process applications where cracks and crevices within the valve need to be minimized. These valves consistently exhibit high performance in pharmaceutical, biotechnological, food, beverage, cosmetic, and other sanitary or clean steam applications and validation systems. Our sanitary valves include:

- Two-Way ball valves
- Flush Tank ball valves
- Diverter Port ball valves
- Multi-Port ball valves
- Steam Trap valves
- Rising Stem Sampling valves

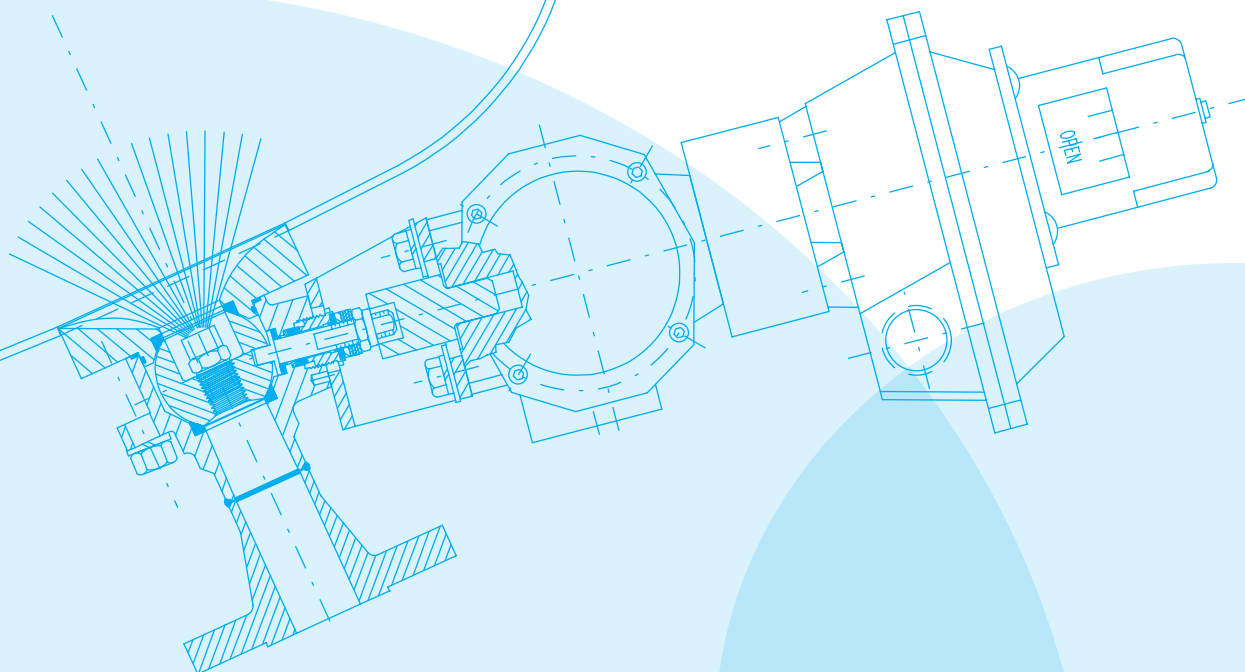



Clean Steam Traps Solutions which are brilliant in their simplicity

TLV's headquarters were founded over half a century ago. TLV is represented by ERIKS for more than 20 years. TLV's goal has been to produce dependable, long-lasting steam traps and products for steam equipments.

TLV is true to the philosophy of complete customer satisfaction through strict adherence to its two fundamental policies: 'Quality first' and 'Incomparable Originality'.

Only through providing superior products and service that are of great benefit to the customer can complete satisfaction be guaranteed. This is the credo that has supported TLV's growth since its inception, and will continue to be the guide into the future.

TLV's quality system is certified to ISO9001, with products and services exceeding the strictest standards and requirements for a wide range of applications.

TLV approaches product developments with continuous dedication to customer needs. Development means the creation of totally new ideas and concepts. The many patents derived through this development process attest to TLV's dedication to innovation.

TLV products meet the needs of the industrial world:

- Longer service life
- Greater energy savings
- Improved quality
- Increased productivity
- Enhanced environmental conservation

Each product is developed with TLV's highest quality and incomparable originality to offer the customer excellent value and service.

TLV is internationally established, with companies in 10 countries. A network of over 100 distributors in more than 50 countries enables the provision of engineering support in any part of the world at any time. TLV plays a leading role in the promotion of efficient energy systems and increased environmental conservation on a worldwide scale through its original products and services.

Clean Steam Traps

Designed for Bio and Clean Steam Applications:

- All Stainless (316L)
- Self-draining
- Crevice-free interior
- Easy Disassembly and Cleaning



Model LV6 Clean Steam Trap

Features

Balanced pressure thermostatic steam trap recommended for use in reactors sterilizers and distribution lines in clean and pure steam systems.

- Free-draining, virtually crevice-free design minimizes the possibility of bacteria buildup.
- Patented 'fall open' feature minimizes interruption of critical operation.
- Large orifice provides high air venting capacity for rapid start-up and resists plugging to ensure continuous operation.
- Compact for easy installation
- Maintainable design lowers cleaning costs.
- LV6P polished to 0.8µm Ra inside and 1.2µm Ra outside with an electro-polish option to further resist bacterial growth.

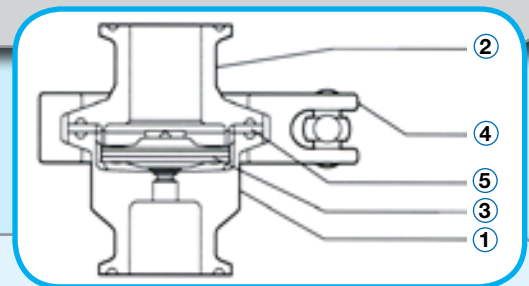

N°	Description	Material*	DIN	ASTM/AISI
①	Lower body	Stainless Steel SUS316L	1.4404	AISI316L
②	Upper body	Stainless Steel SUS316L	1.4404	AISI316L
③	X-element	Stainless Steel SUS316L	1.4404	AISI316L
④	Body Clamp	Cast Stainless Steel S13A	1.4308	A351 Gr. CF-8
⑤	Body Gasket	Fluorine / Ethylene Rubber PTFE/EPDM**	-	-

* Equivalent materials

** Wetted part is PTFE only; PTFE approved to FDA CFR Title 21 Paragraph 177 Section 1550